

COAXIAL T18RE COAX/TVFC

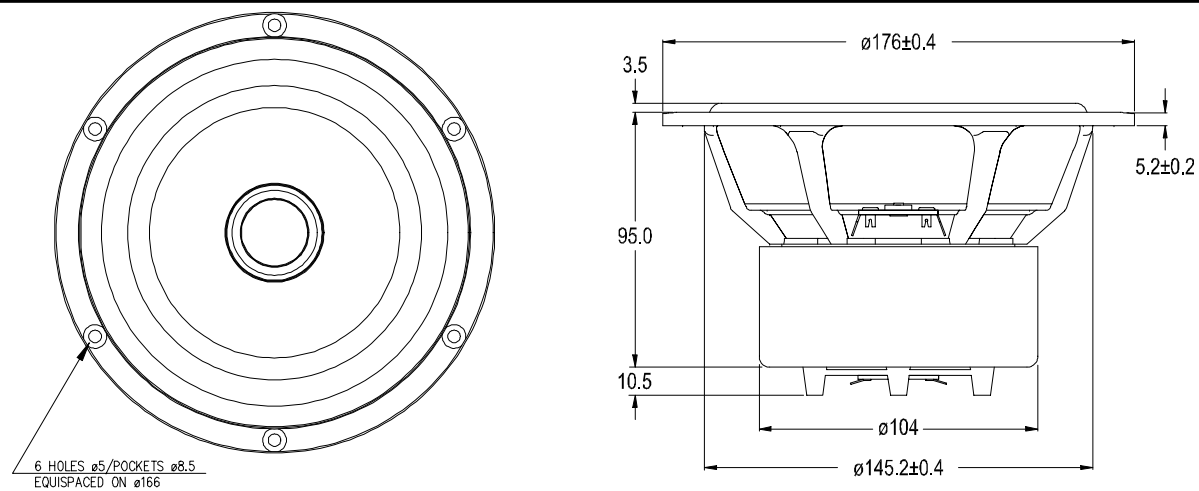

T18RE COAX/TVFC, is a coaxial arrangement of our 6.5" woofer with an XP cone and a precoated fabric dome high frequency unit, with a low resonance frequency.

The cone of the woofer acts as a horn loading for the tweeter, and the chassis of the dome unit represents the throat of this horn. Unlike most traditional coaxial loudspeakers, this arrangement has two advantages: The two drive units have identical acoustic centers, and their directivities in the crossover frequency region are practically identical. Thus, it is possible to build a full range Hi Fi system with a symmetrical and stable radiation pattern combined with a smooth energy response.

A compensation magnet and a shielding cup is mounted on the woofer magnet system to eliminate magnetic stray fields, hence the unit can be used very close to CRT's in audio/video applications.

NOTES

The frequency responses below show measured free field sound pressure in 0, 30, and 60 degrees angle using a standard baffle (IEC 268-5). Input 2.83 Volts RMS, microphone distance 1m. The dotted line is a calculated response for an infinite baffle based on the parameters given for this specific driver

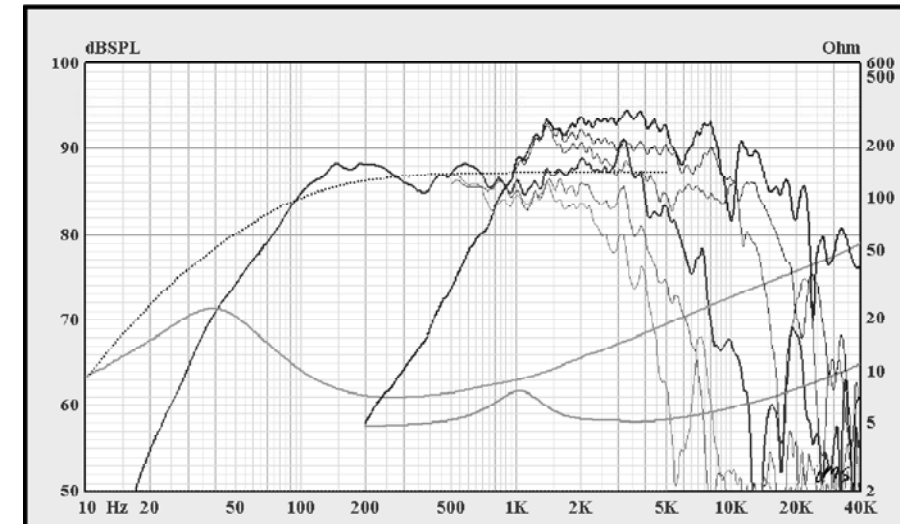

TECHNICAL DATA DOME TWEETER.

NOMINAL IMPEDANCE	6 Ohms	VOICE COIL RESISTANCE	4.8 Ohms
RECOMMENDED FREQUENCY RANGE	2000-25000 Hz	VOICE COIL INDUCTANCE (EQUIVALENT)	0.05 mH
SHORT TERM MAXIMUM POWER *	220 W	VOICE COIL DIAMETER	26 mm
LONG TERM MAXIMUM POWER *	90 W	VOICE COIL HEIGHT	1.5 mm
CHARACTERISTIC SENSITIVITY (1W, 1m)	88,5 dB SPL	MOVING MASS	0.3 g
OPERATING POWER (96 dB SPL, 1 m)	5,6 W	EFFECTIVE PISTON AREA	7.0 sq.cm
		LINEAR COIL TRAVEL (p-p)	0.5 mm
AIR GAP HEIGHT	2.0 mm	FREE AIR RESONANCE	1200 Hz
MAGNETIC GAP FLUX DENSITY	1.2 T		
FORCE FACTOR	2.3 N/A		

* IEC 268-5. VIA HIGH PASS BUTTERWORTH FILTER : 3500 Hz, 12 dB/oct

TECHNICAL DATA CONE DRIVER

NOMINAL IMPEDANCE	8 Ohms	VOICE COIL RESISTANCE	6.1 Ohms
RECOMMENDED FREQUENCY RANGE	40-3000 Hz	VOICE COIL INDUCTANCE (EQUIVALENT)	0.7 mH
SHORT TERM MAXIMUM POWER *	250 W	FORCE FACTOR	6.9 N/A
LONG TERM MAXIMUM POWER *	80 W	FREE AIR RESONANCE	38 Hz
CHARACTERISTIC SENSITIVITY (1W, 1m)	87 dB SPL	MOVING MASS	12.5 g
OPERATING POWER (96 dB SPL, 1 m)	W	AIR LOAD MASS IN IEC BAFFLE	0.8 g
		SUSPENSION COMPLIANCE	1.4 mm/N
VOICE COIL DIAMETER	39 mm	SUSPENSION MECHANICAL RESISTANCE	2.9 Ns/m
VOICE COIL HEIGHT	12 mm	EFFECTIVE PISTON AREA	120 sq.cm
AIR GAP HEIGHT	6 mm		
LINEAR COIL TRAVEL (p-p)	6 mm	VAS	27 Litres
MAXIMUM COIL TRAVEL (p-p)	19 mm	QMS	1.11
		QES	0.41
MAGNETIC GAP FLUX DENSITY	0.87 T	QTS	0.30
MAGNET WEIGHT	0.84 Kg		
TOTAL WEIGHT	2.08 Kg		

* = IEC 268-5