



T29CF001 E0038

The T29CF001 is a High End, High Efficiency 29mm fabric dome tweeter with a wide surround.

An optimally shaped dome and integrated wide surround manufactured by SEAS from SONOMEX ensure excellent performance and consistency.

A powerful magnet system based on an axially magnetized NdFeB ring magnet provides efficient ventilation and damping of the cavity behind the dome. Low viscosity magnetic fluid provides excellent cooling while maintaining a low resonance frequency.

A generously underhung voice coil with flexible lead-out wires ensures low distortion and allow this driver to be used with low crossover frequencies.

A 6mm precision machined aluminum front plate with moderate horn loading combines linear frequency response with high efficiency. The front plate is Nextel painted to obtain a durable and attractive finish.

A substantial injection moulded rear chamber made from zinc eliminates unwanted chamber wall resonances and conducts heat away from the magnet system.

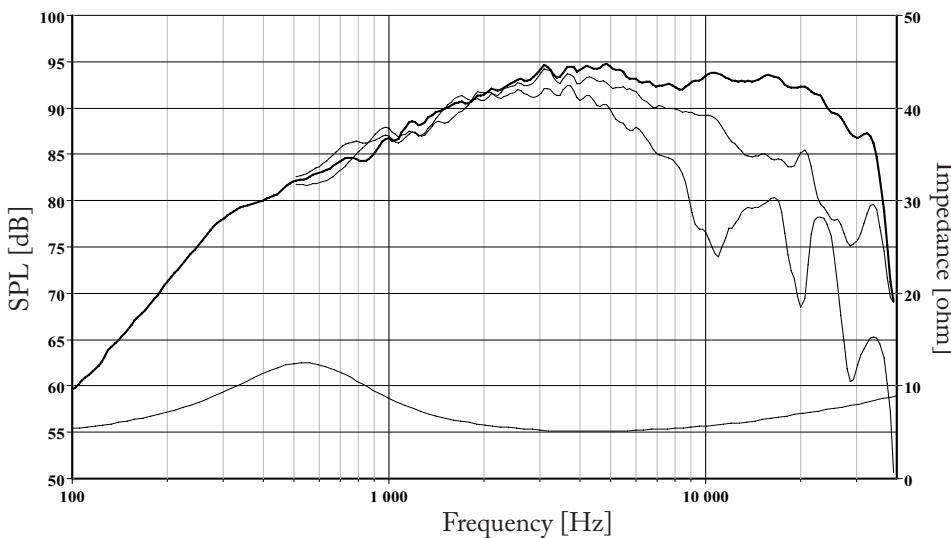

The frequency responses above show measured free field sound pressure in 0, 30, and 60 degrees, mounted in a 0.6m by 0.8m baffle. Input 2.83 V_{RMS}, microphone distance 0.5m, normalized to SPL 1m. The impedance is measured without baffle using a 2V sine signal.

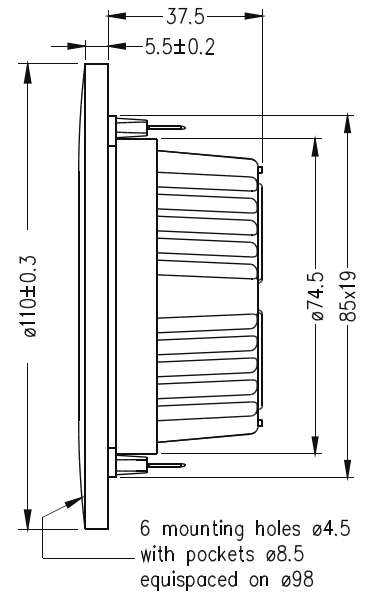

Nominal Impedance	6 Ohms	Voice Coil Resistance	4.7 Ohms
Recommended Frequency Range	2000 - 25000 Hz	Voice Coil Inductance	0.05 mH
Short Term Power Handling *	200 W	Force Factor	3.9 N/A
Long Term Power Handling *	90 W	Free Air Resonance	550 Hz
Characteristic Sensitivity (2.83V, 1m)	93 dB	Moving Mass	0.35 g
Voice Coil Diameter	26 mm	Effective Piston Area	8 cm ²
Voice Coil Height	1.5 mm	Magnetic Gap Flux Density	1.9 T
Air Gap Height	2.5 mm	Magnet Weight	53 g
Linear Coil Travel (p-p)	1 mm	Total Weight	0.67 kg